

HULTDINS TM SuperSaw



SuperSaw 555S

Installation manual
S/N 031-1758 & up

This publication contains instructions for the installation and maintenance of the *SuperSaw 555S* grapple saw units. The instructions cover general information, procedures and specifications applicable to this grapple saw. If doubt should arise concerning the validity of the instructions please consult the nearest dealer for more detailed information.

Illustrations, technical information and specifications were, as far as we have been able to judge, correct at the time of print. However, we reserve the right to, without prior notice, revise specifications, instructions, equipment, etc. as a result of ongoing product improvement activities.

No part of this publication may without approval of HULTDIN SYSTEM AB be translated, reproduced, stored or transmitted electronically, mechanically, photographically or in another way not specified here.

Even if all conceivable measures have been taken to make the contents as complete as possible, HULTDIN SYSTEM AB takes no responsibility for possible damages that may arise as a result of the instructions not being followed or improper use of the product

 **Important!**

The parts and components used in HULTDIN SYSTEM AB's products are specifically chosen. Therefore original spare parts are always the best alternative in a possible need of repairs or upgrading.

All service and repairs should be carried out by qualified service personnel or an authorized repair shop with suitable tools and lifting devices.

This publication is published by: HULTDIN SYSTEM AB
Skolgatan 12
SE-930 70 MALÅ
Sweden

This publication applies to the following models:

SuperSaw 555S S/N 031-1758 & up

Contents	Page	Contents	Page
Safety instructions	5	Installation	23
General safety.....	5	Where to install the grapple saw?	23
Meaning of safety messages.....	5	Installing rotator bracket	24
Operational Safety.....	6	Hydraulic installation	25
Chain shot hazard.....	6	Installing HD rotator bracket	26
Operator and bystander safety	6	Hydraulic installation	27
Maintenance safety.....	7	SuperGrip TL installation	28
Welding.....	7	Hydraulic installation	29
Modifying the equipment	7	Initial upstart	30
Product description	8	Saw motor upstart	30
Main parts, Grapple saw	8	Adjusting saw bar feed out pressure	31
Adjustment valves, Grapple saw	9	Adjusting saw bar feed out.....	32
Hydraulic pressure test points	10	Adjusting saw bar retraction	32
Hydraulic connections.....	11	Adjusting chain tension pressure	33
Main parts SuperCut	12	Bleeding the chain tension system	33
Labeling.....	13	Procedures	34
Technical Data	14	Replacing saw chain.....	34
SuperSaw 555S - 19cc	14	Replacing saw bar	35
Rotator bracket	15	Replacing bar holder	36
Rotator bracket HD	16	Replacing drive sprocket.....	37
SuperGrip TL mtg. bracket	17	Refilling chain lubrication oil	38
Special tools	18	Maintenance instructions	39
Hydraulic diagram SuperSaw 555S / alt. 1	19	Regular maintenance	39
Hydraulic diagram SuperSaw 555S / alt. 2	20	Daily maintenance	39
Hydraulic diagram SuperSaw 555S / alt. 3	21	Lubrication	40
Functional description	22	The first month of operation	40
Chain lubrication system.....	22	Fasteners	40

(This page is reserved for future additions)

Safety instructions

General safety

- This page describes important safety instructions, which the operator should have a good knowledge of before the equipment is used.
- This product should only be used by operators with proper knowledge and training.
- The owner and the operator are responsible for following all safety regulations and that the machine is safely equipped.
- The owner and the operator are responsible for following National and local laws, regulations and other instructions when using the product.
- The owner and the operator are responsible for replacing damaged parts and/or unreadable warning signs.
- The manual should be available at all times so that the operator is able to follow safety regulations and the procedures of maintenance activities.



Meaning of safety messages



Danger!

Danger indicates a hazard with a high level of risk which, if not avoided, will result in death, serious injury and/or serious property damage.



Warning!

Warning indicates a hazard with a medium level of risk which, if not avoided, could result in death, serious injury and/or serious property damage.



Caution!

Caution indicates a hazard with a low level of risk which, if not avoided, could result in minor or moderate injury and/or property damage

Operational Safety

- Check the unit for damages at the beginning of each shift.
- Make sure that the hydraulic pressure in the grapple cylinder is adjusted according to the specifications. If the pressure is too high, the unit will be overloaded, which could cause a structural failure, resulting in injury and/or property damage.
- When operating this equipment ensure all unauthorized persons remain at least 90 meters clear of the machine.
- The operator must immediately evict unauthorized persons who are in the danger zone or are heading towards the danger zone
- Training or demonstration of this equipment should be performed from an operator's cab approved by national regulations. Observers should always remain at least 90 meters.
- Keep all windows and doors securely closed when operating.

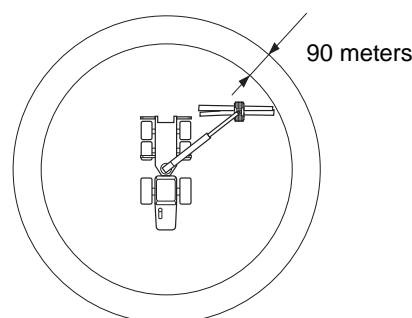

Chain shot hazard

Operator and bystander safety

Because of the high speeds, high stress, heavy loads, wear factors and varying levels of repair and maintenance given to saw-chain based machines, there is a possibility that chain or chain pieces can be thrown from the machine at high speed and enormous energy. Operators and bystanders are exposed to a risk of serious injury.

Machines should be designed with appropriate guards and shields, and care should be taken to minimize the exposure of users and bystanders to the cutting plane of the saw.

- There is risk of serious injury or death to machine operators and bystanders from “Chain Shot”, which is the high-speed ejection of chain parts that can occur in the event of a derailed or a broken chain. For maximum protection, machines should be equipped with an energy-absorbing chain shot guard.
- Always use High Speed saw chains with 3/4” pitch saw units.



Maintenance safety

- The machine's condition must be checked regularly, daily inspections shall be performed and any deficiencies must be corrected. The machine shall be maintained in such condition that the operator or other persons are not exposed to danger or accidents.
- Never commit any service on the equipment without proper knowledge. All service and repairs in electrical and hydraulic systems should be carried out by qualified personnel only.
- Repair any damages immediately when discovered. Do not use the equipment until any damages are rectified.
- Before performing any maintenance or service work, lower the unit to the ground and shut off the engine. Turn off any master shut-offs and do not allow personnel in the cab.
- When working on the saw chain always ensure the engine is shut off and wear safety gloves to prevent injuries. Remove the saw chain when making any adjustments or servicing the saw unit
- Use safety glasses and protective gloves when servicing the equipment. Hydraulic oil or lubricants in contact with skin or eyes may cause irritations or allergies.
- Use hard hat and safety boots when servicing the equipment. Leakage of hydraulic oil or lubricants will increase the risk of slipping or falling.
- The unit has sharp edges. Use proper wrenches and protective gloves when working on the unit.
- Hydraulic hoses and adapters may be pressurized even with the engine shut off. Loosen any parts with caution.
- Always make sure that the system is depressurized before committing any service on the equipment.
- Always secure movable parts mechanically before any hydraulic hose is loosened.
- Never try to stop a leakage in the hydraulic system with you hand. Pressurized hydraulic oil can be injected under the skin and cause death or severe damage.



Welding

In case of a structural repair of the equipment, when welding may be needed, consult the dealer for recommended instructions.

When welding on the equipment the following steps must be taken:

- Make sure that fire-extinguishing equipment is available.
- Clean the area around the welding area to eliminate any fire hazard.
- Connect the ground wire so the welding current does not pass over any bushings.
- Place the ground wire as close to the welding area as possible.
- When welding close to bushings, disassemble the bushings as they are made of a plastic compound-material which high temperatures may damage.

Modifying the equipment

It is not approved to:

- Modify the equipment without the consent of HULTDIN SYSTEM AB.
- Alter the function of the equipment without the consent of HULTDIN SYSTEM AB.
- Use spare parts other than original HULTDINS parts.

Product description

Main parts, Grapple saw

The *SuperSaw 555S* grapple saw consists basically of a frame, a saw unit and a hydraulic system. The illustration shows the location of the main parts.

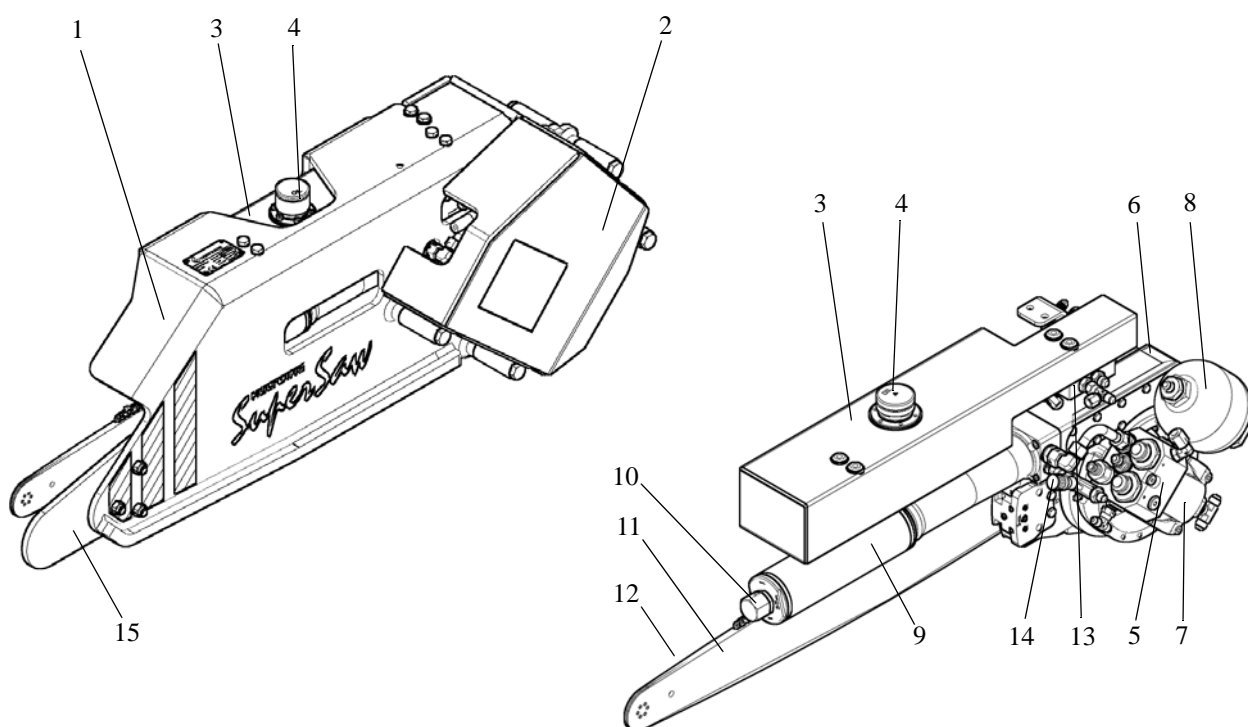
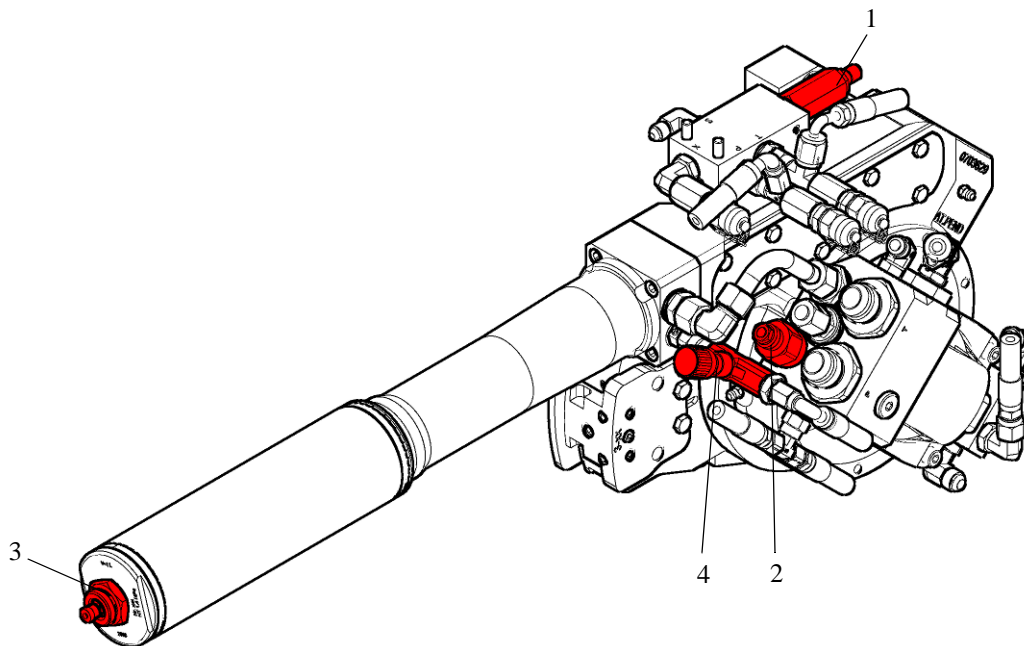

Fig. 1 Main parts SuperSaw 555S

- 1 Frame
- 2 Saw motor cover
- 3 Lubrication oil tank
- 4 Refilling cap for chain lubrication oil
- 5 Saw motor manifold with adjusting valve for saw bar feed out pressure
- 6 Saw unit
- 7 Saw motor
- 8 Accumulator for saw motor case drain
- 9 Air tank for saw bar retraction
- 10 Air nippel for air-pressure adjustment
- 11 Saw bar
- 12 Saw chain
- 13 Adjustment valve for chain tension pressure
- 14 Restrictor valve for saw bar feed out adjustment
- 15 Cover plate (100 cm saw bar)

Adjustment valves, Grapple saw

The *SuperSaw 555S* grapple saw has the following adjustment valves. The location of the valves shows on the illustration.



ill. 2 Adjustment valves

- 1 Pressure regulating valve for saw chain tension pressure
- 2 Pressure regulating valve for saw bar feed out pressure
- 3 Air nipple for saw bar retraction adjustment
- 4 Restrictor check valve for saw bar feed out adjustment

Hydraulic pressure test points

The *SuperSaw 555S* grapple saw has three different hydraulic pressure test points, as shown on the following illustration.

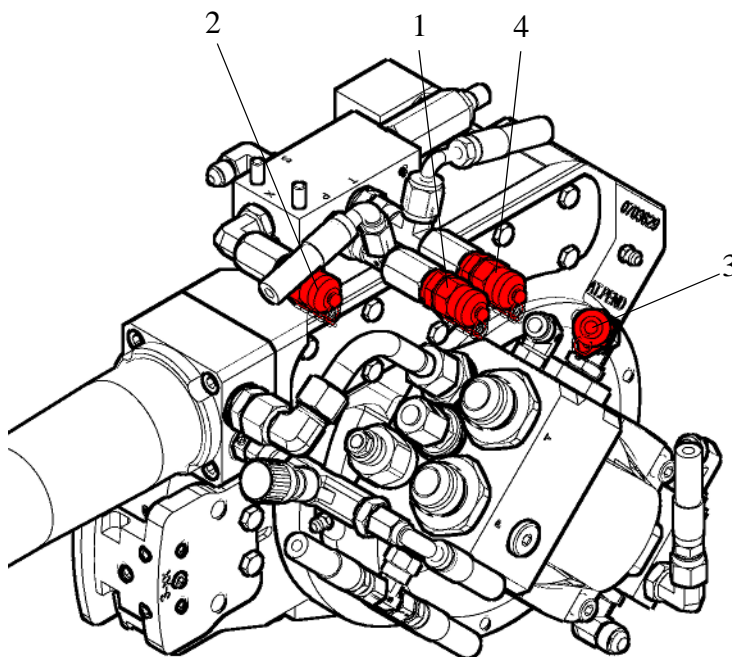

ill. 3 Hydraulic pressure test points

- 1 Test point for saw bar feed out pressure
- 2 Test point for chain tension pressure
- 3 Test point for saw motor return line pressure
- 4 Test point for drain line

Hydraulic connections

The *SuperSaw 555S* grapple saw is hydraulically installed with the following three connection ports.

The location of the ports shows on the following illustration.

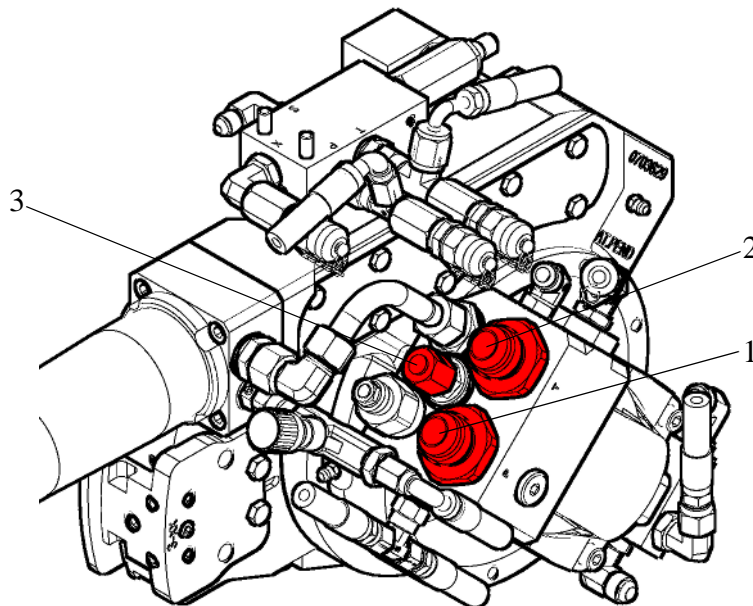

ill. 4 Hydraulic connections

- 1 Saw motor pressure line
- 2 Saw motor return line
- 3 Saw motor case drain line (option)

Product description

Main parts SuperCut

The SuperCut saw unit is made up of the following main parts.

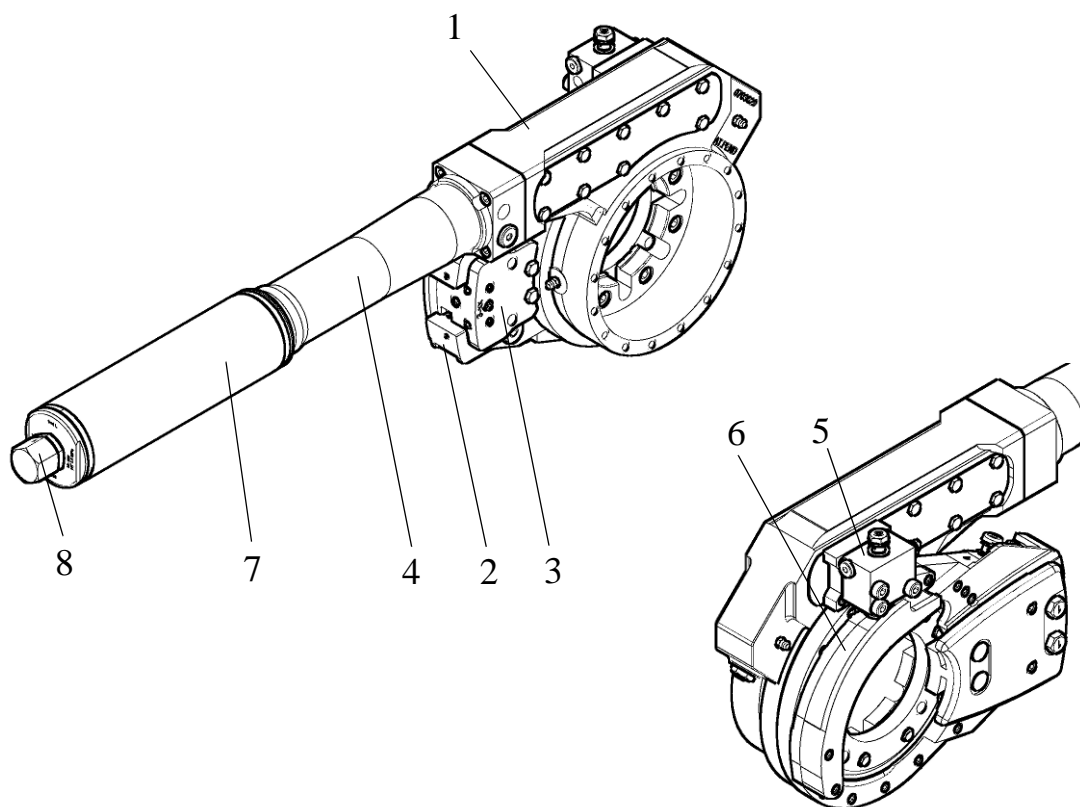

ill. 5 Main parts SuperCut

1. Housing
2. Tension device
3. Bar holder
4. Feed out cylinder
5. Lubrication oil pump
6. Cam
7. Air tank for saw bar retraction
8. Air nipple for air-pressure adjustment

Product description

The *SuperSaw 555S* grapple saw, which together with SuperGrip, SuperGrip II or SuperGrip TL grapples is generally mounted on cranes intended for on road- and off road vehicles. *SuperSaw 555S* is only intended to be used for timber, pulp- and waste wood systems.

SuperSaw 555S must not be used for felling applications, as there is a risk that the grapple arms or other parts of the grapple or grapple saw may fail, which could result in injury or damaged equipment.

Labeling

SuperSaw 555S is labeled with serial number, model number, mfg. year, weight and a CE-label according to the following illustration.

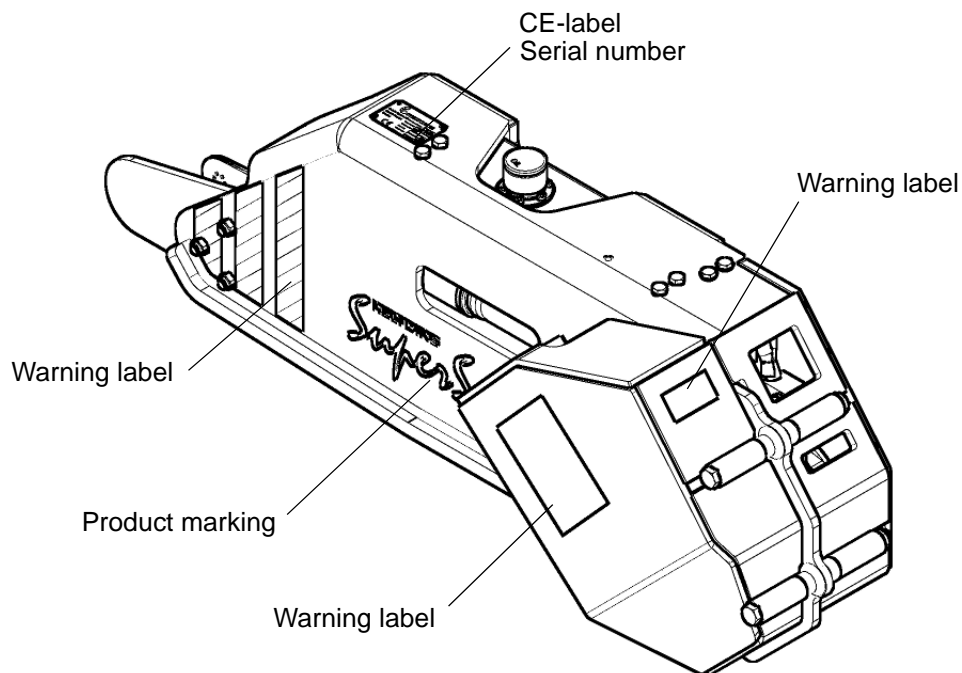

Technical Data

SuperSaw 555S - 19cc

Dimensions

Total weight .404"	165 kg (90cm) 168 kg (100cm)
Length 'A'	1195 mm (90cm) 1335 mm (100cm)
Width 'B'	184 mm
Height 'C'	465 mm
Width 'D'	148 mm
Saw bar .404"	90 cm / 100 cm

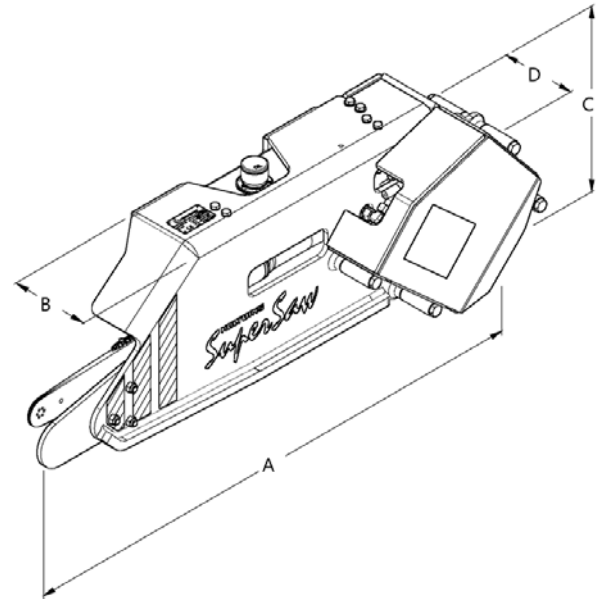

Hydraulic system

Saw motor displacement	19 cm ³
Min. hydraulic pressure, saw motor	16,0 MPa*
Min. hydraulic flow, saw motor	125 lpm *
Hyd. pressure, saw bar feed out 'P1'	7,5 - 8,5 MPa
Hyd. pressure, chain tensioning 'P2'	3,0 MPa
Gas pressure, accumulator 'P3'	0,1 MPa
Air pressure, saw bar retraction 'P4'	1,2 - 1,4 MPa

Chain lubrication

Type of lubrication	Proportional
Lub. oil tank capacity	6,5 lit.

* Max. saw chain speed and Max. power input to the saw chain may NEVER exceed recommendations from each saw chain manufacturer.

Technical Data

Rotator bracket

Dimensions

Total weight incl. hoses	48 kg
Length 'A'	90 mm
Length 'B'	192 mm
Height 'C'	64 mm
Rotator hole pattern	M16 / 173 mm

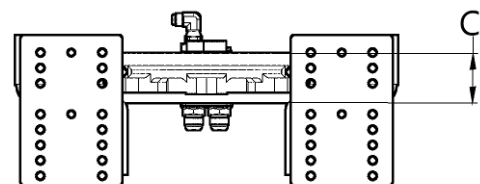
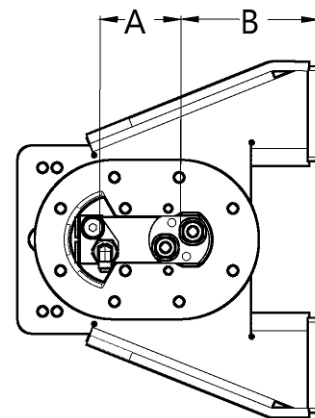
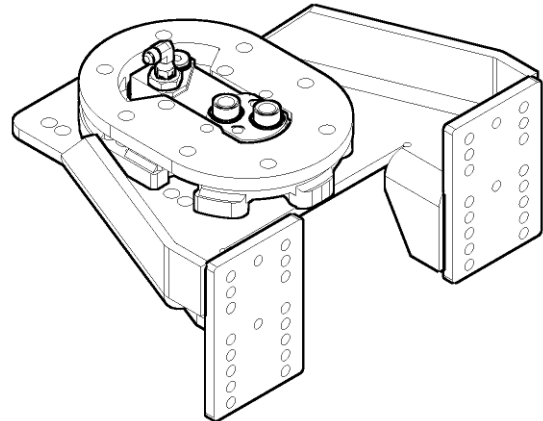

Rotator bracket HD

Dimensions

Total weight incl. hoses	88 kg
Length 'A'	175 mm
Length 'B'	149,5 mm
Height 'C'	170 mm
Rotator hole pattern	M16 / 173mm M20 / 203mm

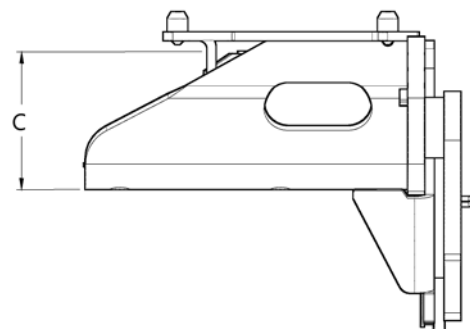
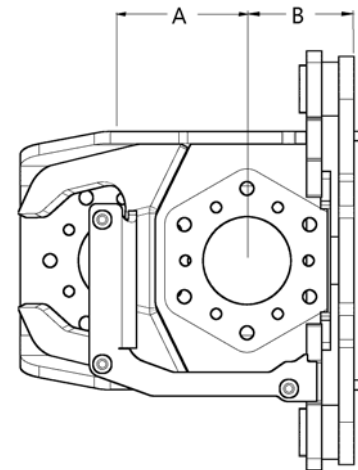
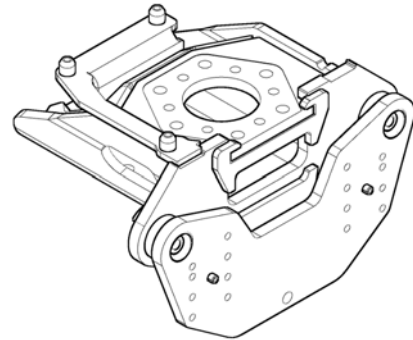

SuperGrip TL mtg. bracket

Dimensions

Total weight incl. hoses	26 kg
Length 'A'	240 mm

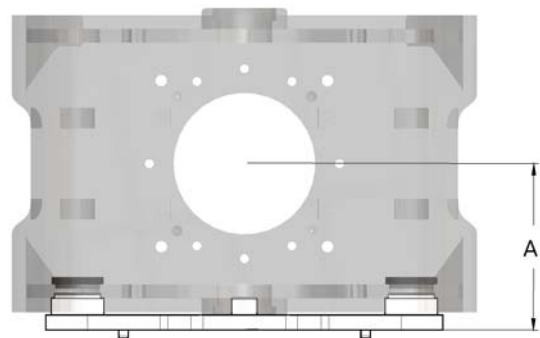
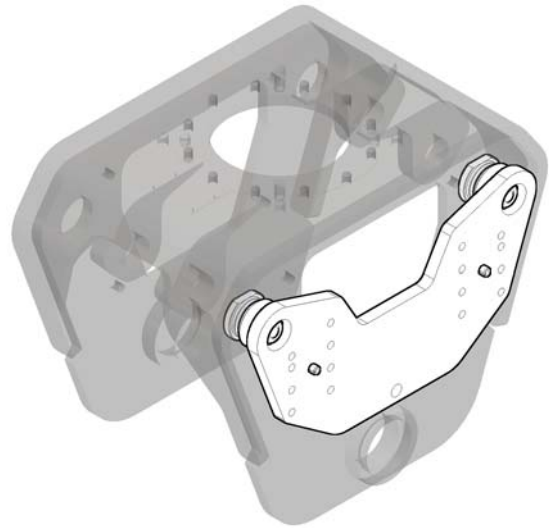

Special tools

The following special tools are supplied with the unit and required when servicing SuperSaw 555S.

Air pump

The air-pump is used when adjusting the saw bar retraction speed. *See ill. 6.*

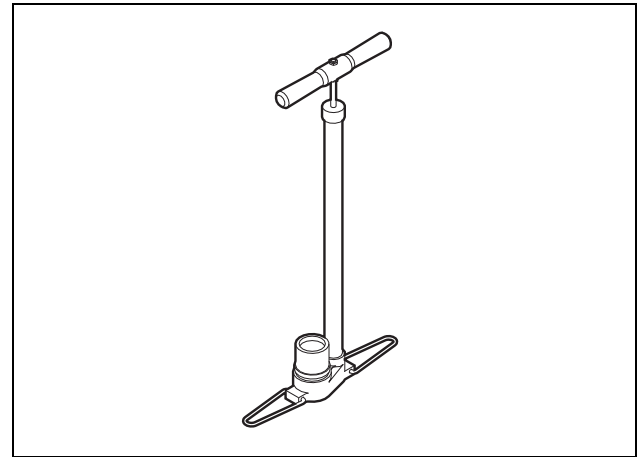

ill. 6 Air-pump, P/N 0138042

Installation tool

The installation tool, P/N 0690149, is required when replacing the check valve for the chain tensioning. *See ill. 7.*

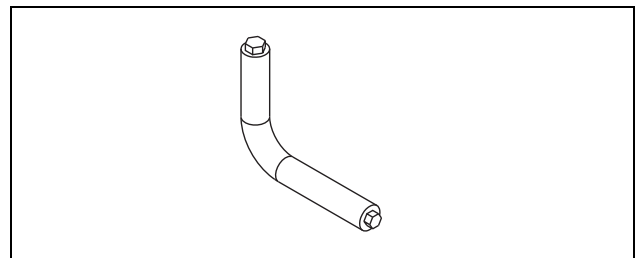

ill. 7 Installation tool, P/N 0690149

Check valve key

The check valve key, P/N 0696011, is required when replacing the check valve for the chain lubrication. It is also used when bleeding the chain tensioning circuit. *See ill. 8.*

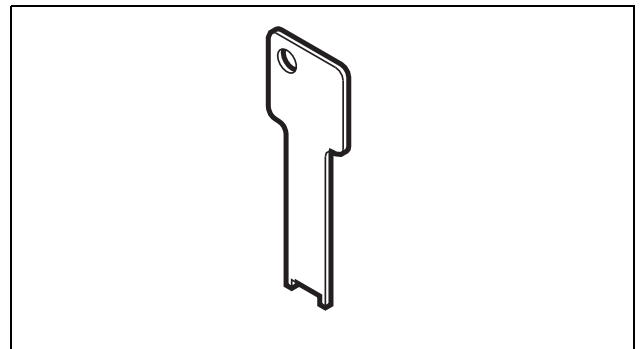

ill. 8 Check valve key, P/N 0696011

Hydraulic diagram SuperSaw 555S / alt. 1

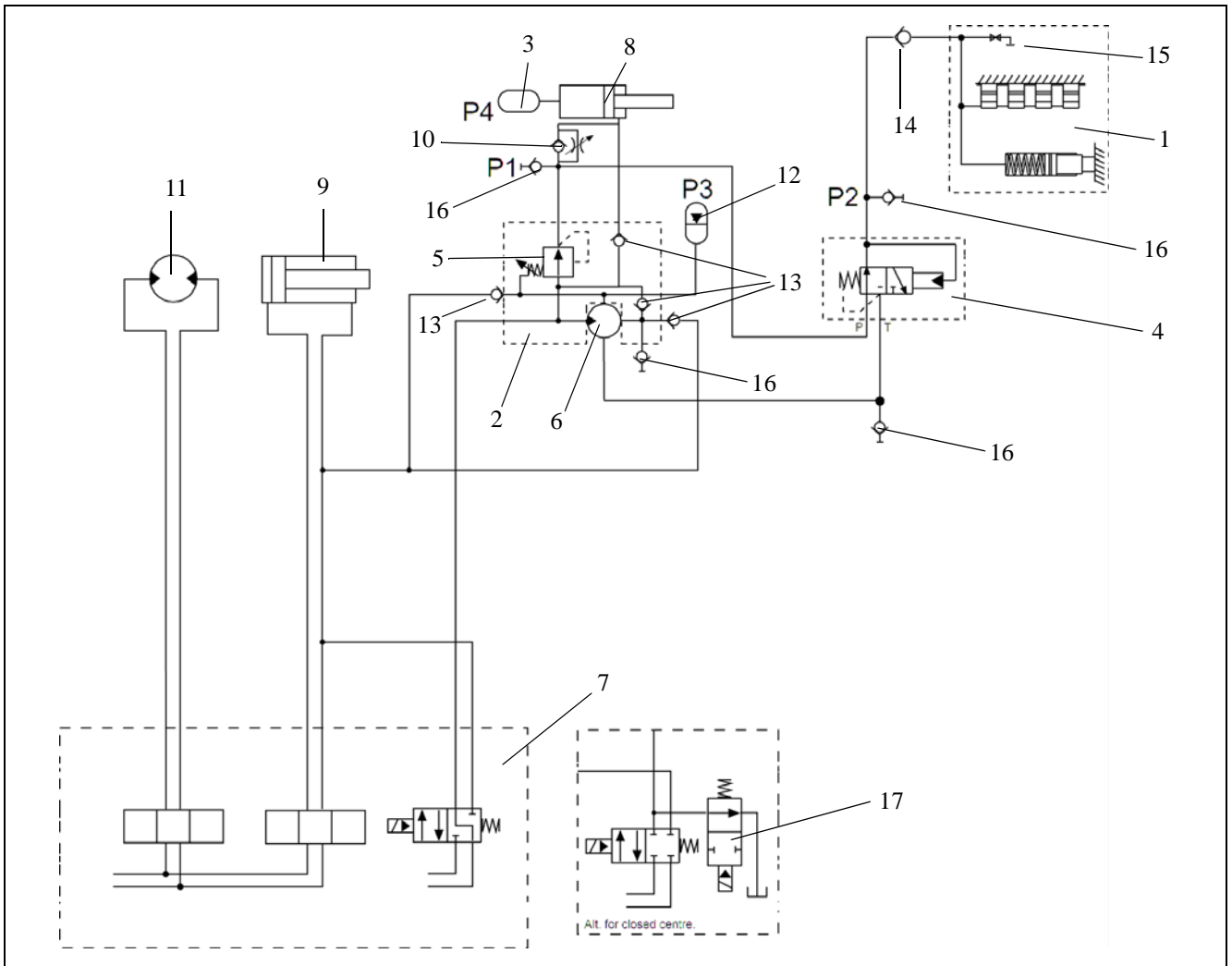

ill. 9 Hydraulic diagram

- | | |
|--|--|
| 1. Tension device | 11. Rotator |
| 2. Saw motor manifold | 12. Accumulator for saw motor case drain |
| 3. Air tank for saw bar retraction | 13. Check valve |
| 4. Pressure regulating valve for chain tensioning | 14. Check valve for chain tensioning |
| 5. Pressure regulating valve for saw bar feed out pressure | 15. Bleed valve for chain tensioning |
| 6. Saw motor | 16. Pressure test point |
| 7. Main valve on carrier* | 17. Dump valve* |
| 8. Saw bar feed out cylinder | |
| 9. Grapple cylinder | |
| 10. Check restrictor valve for saw bar feed out | |

* Required on carrier, but not supplied with the grapple saw.

Hydraulic diagram SuperSaw 555S / alt. 2

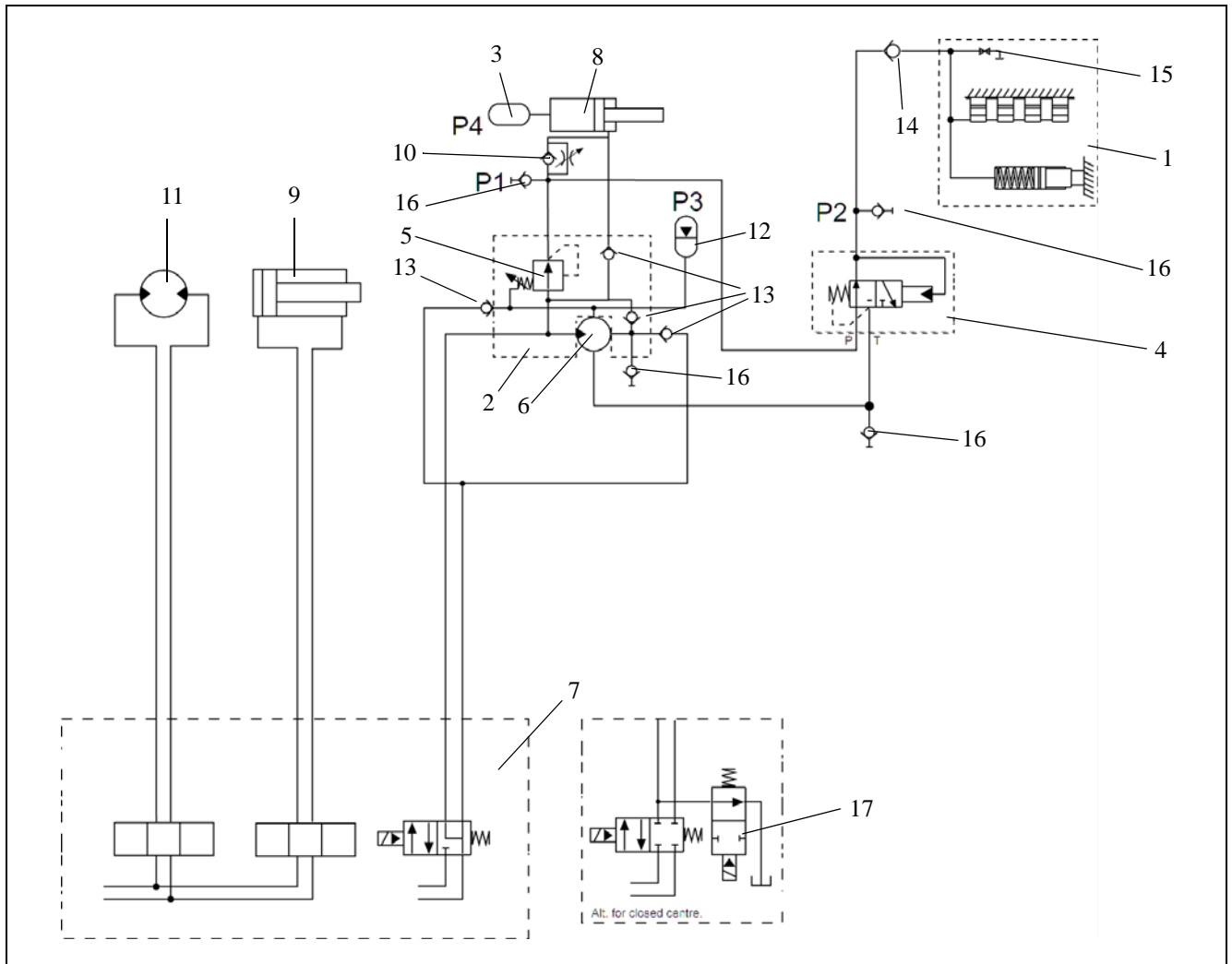

ill. 10 Hydraulic diagram

- | | |
|--|--|
| <ul style="list-style-type: none"> 1. Tension device 2. Saw motor manifold 3. Air tank for saw bar retraction 4. Pressure regulating valve for chain tensioning 5. Pressure regulating valve for saw bar feed out pressure 6. Saw motor 7. Main valve on carrier* 8. Saw bar feed out cylinder 9. Grapple cylinder 10. Check restrictor valve for saw bar feed out | <ul style="list-style-type: none"> 11. Rotator 12. Accumulator for saw motor case drain 13. Check valve 14. Check valve for chain tensioning 15. Bleed valve for chain tensioning 16. Pressure test point 17. Dump valve* |
|--|--|

* Required on carrier, but not supplied with the grapple saw.

Hydraulic diagram SuperSaw 555S / alt. 3

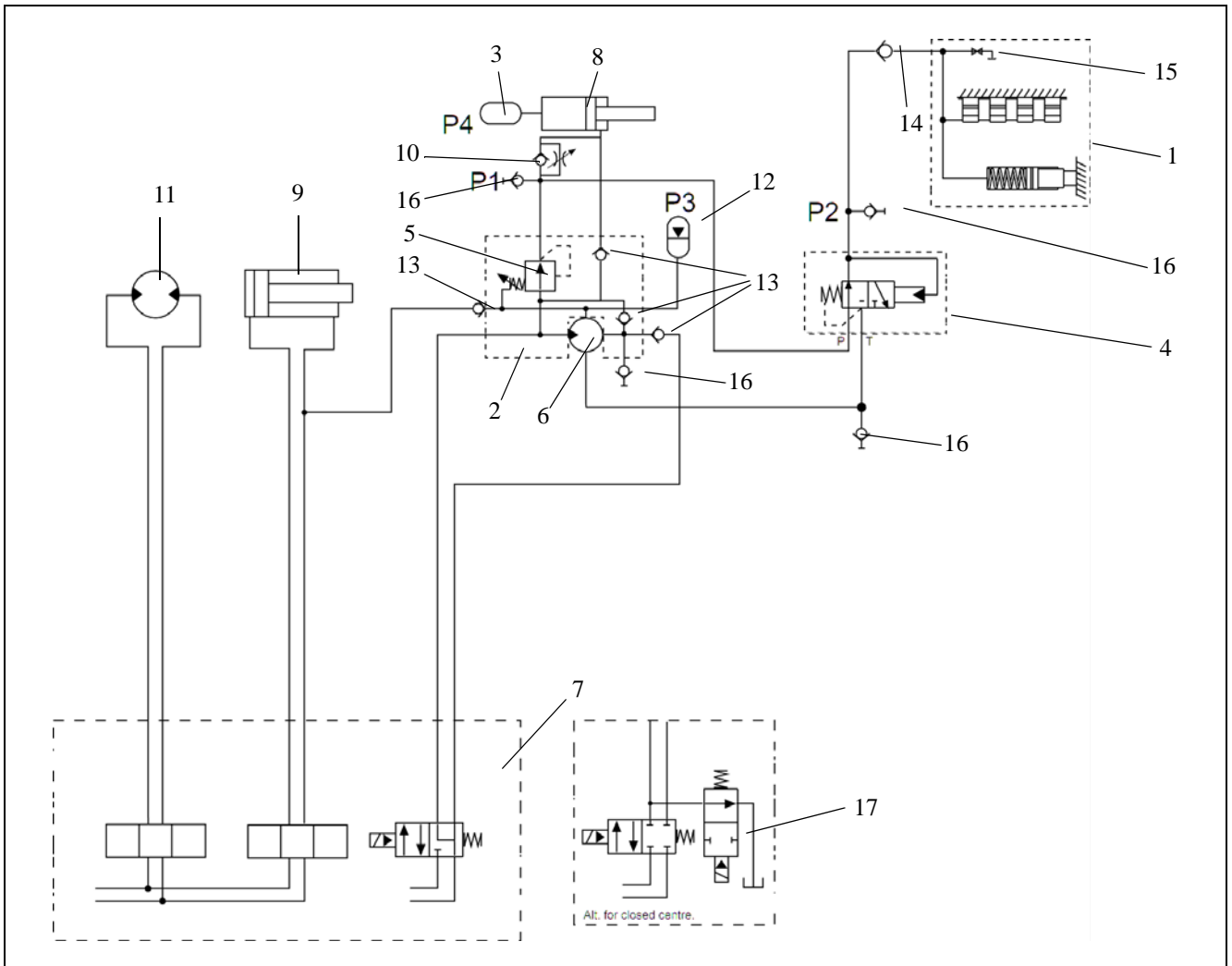

ill. 11 Hydraulic diagram

- | | |
|--|---|
| <ul style="list-style-type: none"> 1. Tension device 2. Saw motor manifold 3. Air tank for saw bar retraction 4. Pressure regulating valve for chain tensioning 5. Pressure regulating valve for saw bar feed out pressure 6. Saw motor 7. Main valve on carrier* 8. Saw bar feed out cylinder 9. Grapple cylinder 10. Check restrictor valve for saw bar feed out | <ul style="list-style-type: none"> 11. Rotator 12. Accumulator for saw motor case drain 13. Check valve 14. Check valve for chain tensioning 15. Bleed valve for chain tensioning 16. Pressure test point 17. Dump valve* <p>* Required on carrier, but not supplied with the grapple saw.</p> |
|--|---|

Functional description

Chain lubrication system

SuperCut is equipped with a M06 lubrication pump.

The lubrication oil pump supplies oil during the entire feed out process.

The lubrication oil pump (1) is a piston pump operated by a cam(3), attached to the saw unit. During the saw bar feed out process, the cam (3) will compress the piston (2) and chain lubrication oil is fed out to the saw bar.

The volume of oil that is supplied to the saw bar depends on how much the piston (2) is compressed.

The lubrication volume can be adjusted by replacing the cam (3).

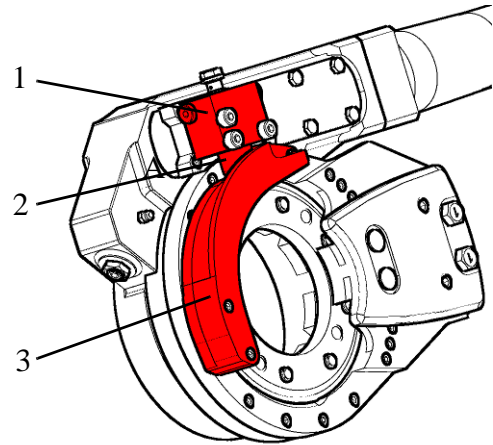

Fig. 12 Chain lubrication system

1. Lubrication oil pump M06
2. Piston
3. Cam

Installation

Where to install the grapple saw?

SuperSaw 555S should normally be installed with the saw motor on the same side as the piston rod of the grapple cylinder, to achieve the best weight balance.

On the A-models of the SuperGrip II grapples, the SuperSaw 555S should be installed on the same side as the longer tips of the grapple arms, to optimize the performance of the grapple saw together with the grapple.

The grapple saw should be installed with a Min. distance of 70 mm from the saw chain to the log, with the saw bar fully retracted.

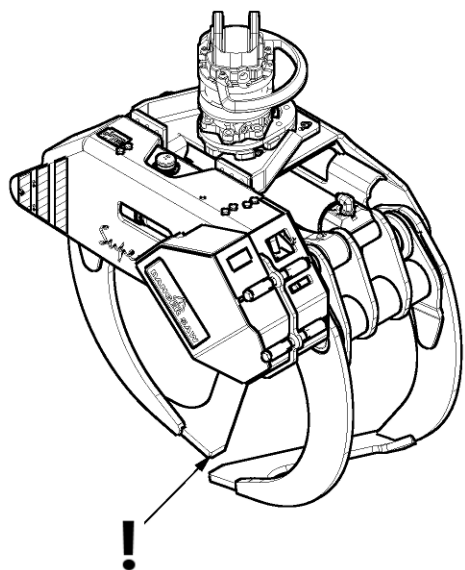
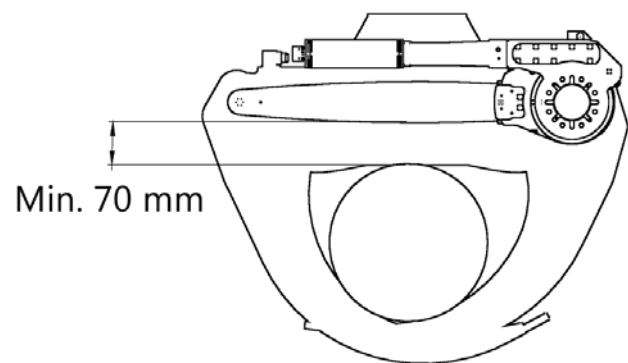
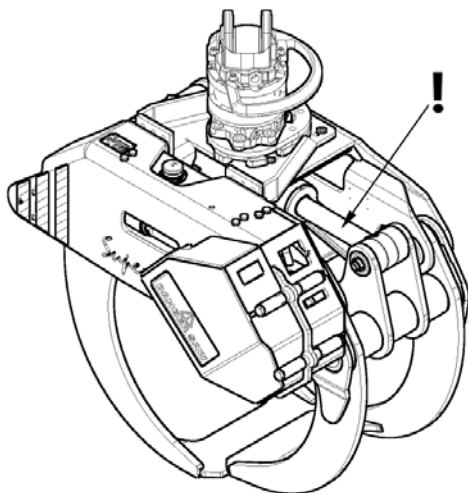

Installing rotator bracket

1. Assemble the manifold (1) to the rotator (2). Tighten the collar screws (3) with the correct torque according to the following chart.

Torque

Size	Torque
G1/2"	100 Nm
G3/4"	170 Nm

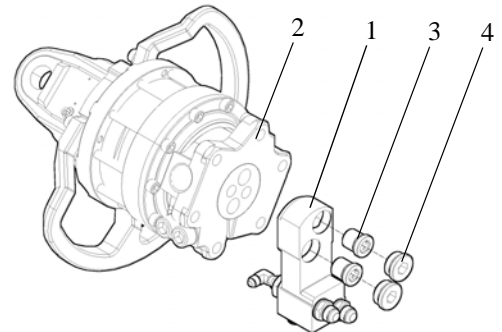

ill. 13 Assemble the manifold to the rotator

2. Assemble the spacer (1) to the rotator (2).
Torque 266 Nm, M16, 6 pcs.

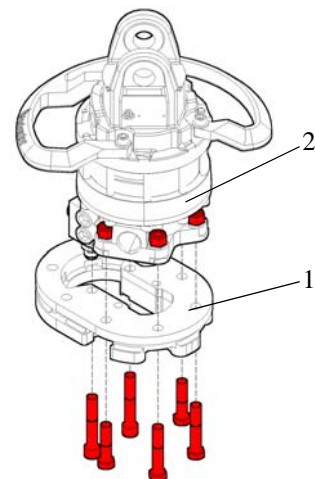

ill. 14 Assemble the spacer to the rotator

3. Assemble the rotator asm. and the rotator bracket to the grapple.
Torque 266 Nm, M16, 10 pcs (6 pcs).

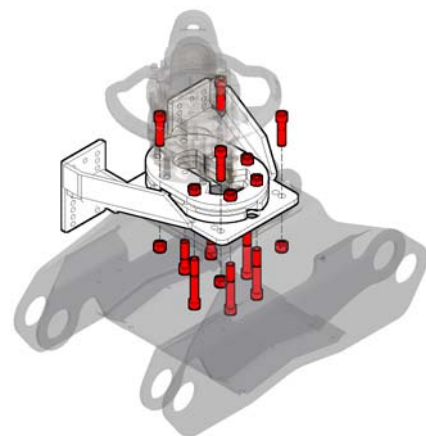

ill. 15 Assemble the rotator asm. and the rotator bracket to the grapple

4. Assemble the grapple saw to the rotator bracket.
Torque 130 Nm, M12, 12 pcs.

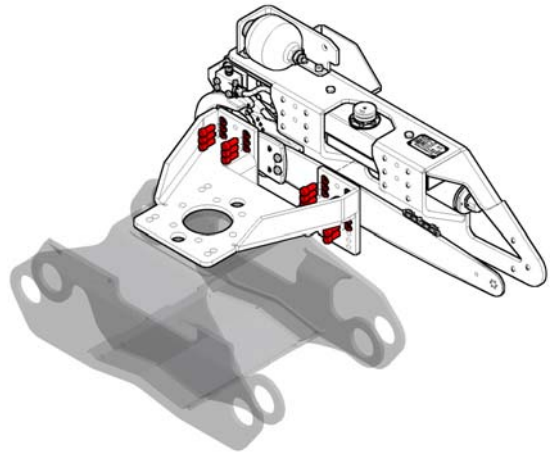

ill. 16 Assemble the grapple saw to the rotator bracket

Hydraulic installation

1. Connect the saw motor pressure line to port “1” on the rotator.
2. Connect the saw motor return line to port “2” on the rotator.
3. Connect the saw motor drain line to port “0” at the back of the rotator manifold.
4. Connect the hoses from the grapple cylinder to the connections at the bottom of the rotator manifold.
5. Start the machine and test all functions to make sure that everything is working properly.

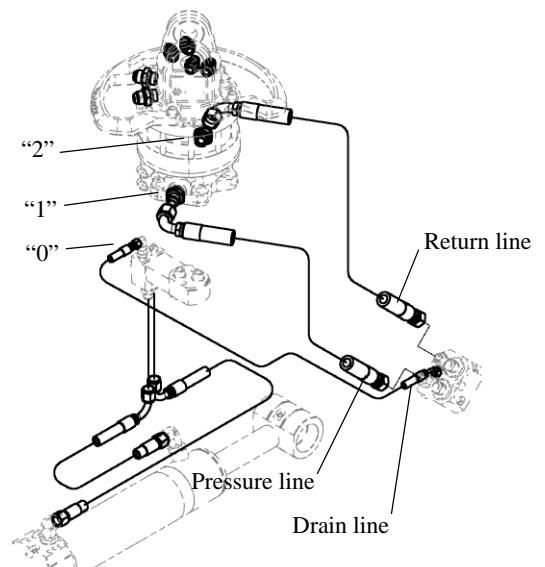

ill. 17 Hydraulic installation

Installing HD rotator bracket

1. Assemble the rotator bracket with the grapple.
Torque 320 Nm, M16, 6pcs.

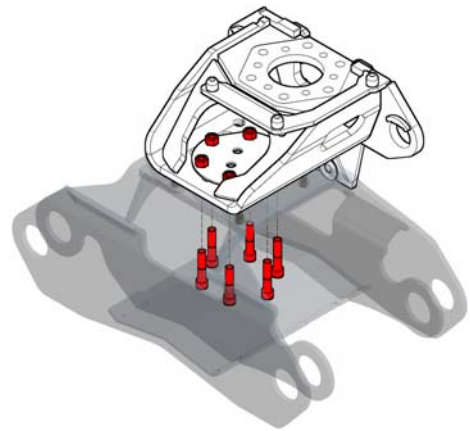

ill. 18 Assemble the rotator bracket with the grapple

2. Assemble the mtg. plate with the grapple saw.
Torque 130 Nm, M12, 14 pcs.

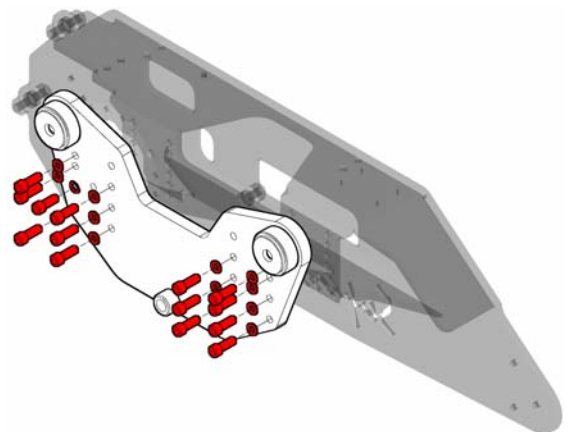

ill. 19 Assemble the mtg. plate with the grapple saw

3. Install the grapple saw asm. onto the rotator bracket.
Torque 620 Nm, M20, 3pcs.

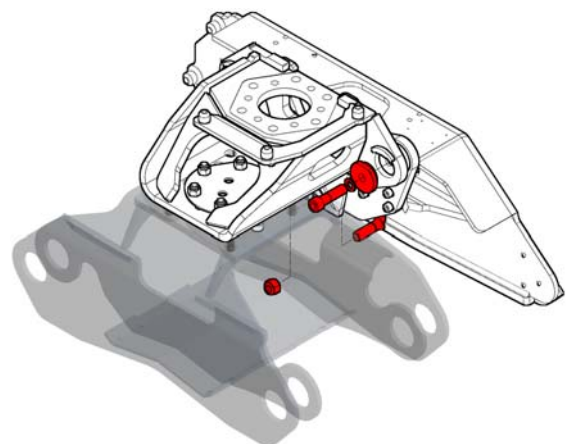

ill. 20 Install the grapple saw asm. onto the rotator bracket

4. Install the rotator onto the rotator bracket
Tighten the fasteners according to the following chart.

Size	Torque
M16	320 Nm
M20	620 Nm

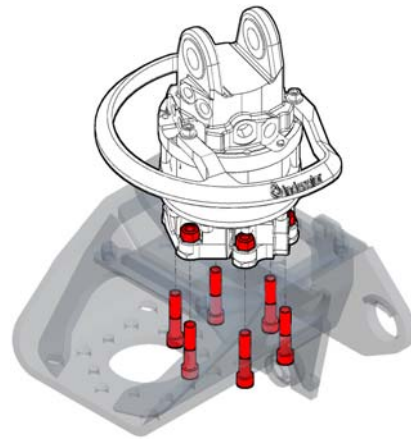

ill. 21 Install the rotator onto the rotator bracket

Hydraulic installation

1. Connect the saw motor pressure line to port “1” on the rotator.
2. Connect the saw motor return line to port “2” on the rotator.
3. Connect the hoses from the grapple cylinder to the connections at the bottom of the rotator manifold.
4. Start the machine and test all functions to make sure that everything is working properly

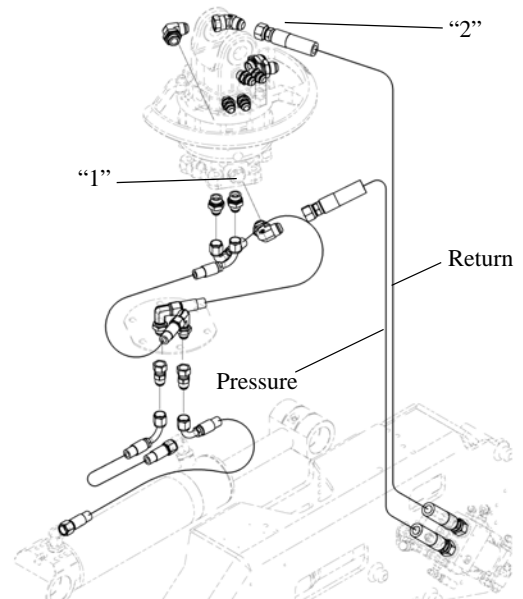

ill. 22 Hydraulic installation

SuperGrip TL installation

1. Assemble the mtg. plate with the grapple saw.
Torque 130 Nm, M12, 16 pcs.

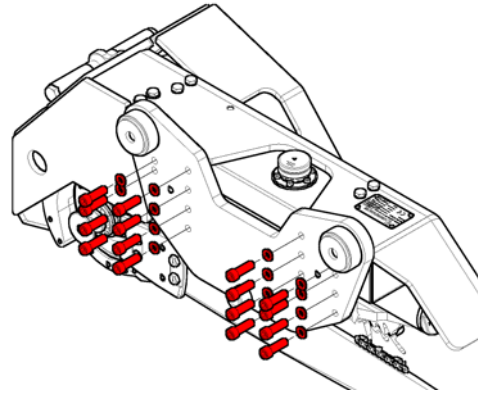

ill. 23 Assemble the mtg. plate with the grapple saw

2. Install the grapple saw asm. to the grapple.
Torque 620 Nm, M20, 3pcs.

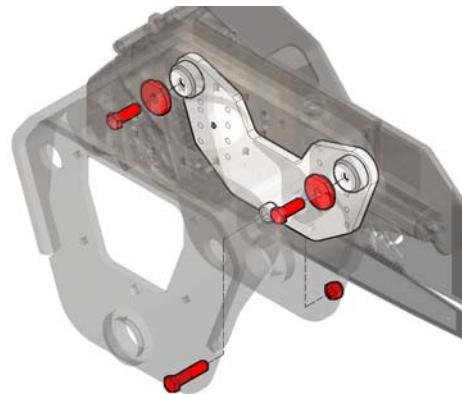

ill. 24 Install the grapple saw asm. to the grapple

Hydraulic installation

1. Connect the saw motor pressure line to port “X” on the rotator.
2. Connect the saw motor return line to port “G0” on the rotator.
3. Start the machine and test all functions to make sure that everything is working properly

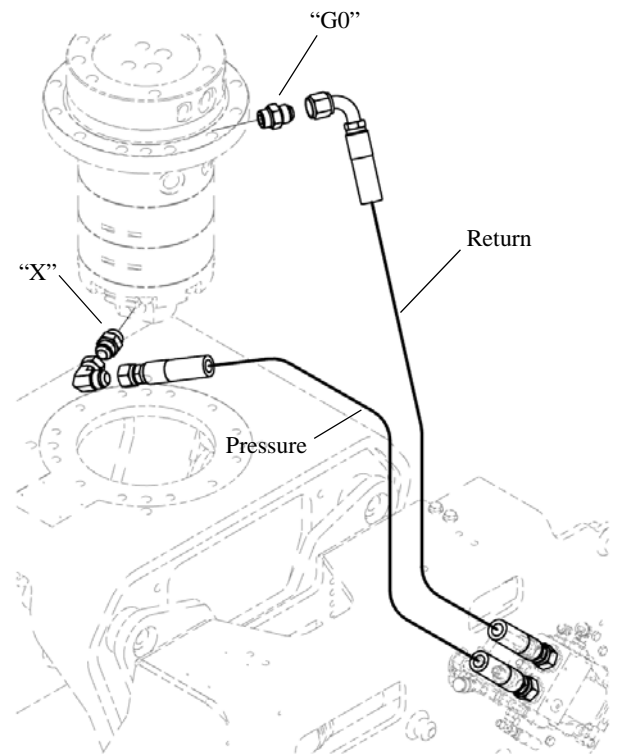

ill. 25 Hydraulic installation

Initial upstart

Saw motor upstart

 **Important!**
Fill the saw motor casing with hydraulic oil before starting the motor.

 **Important!**
The warranty will not be valid if the motor is disassembled.

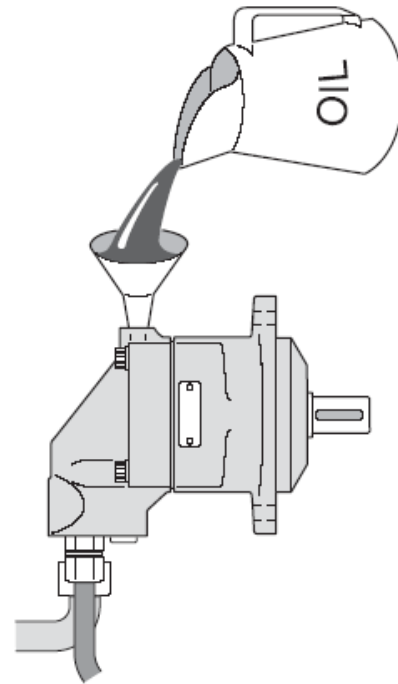

ill. 26 Fill the casing with hydraulic oil before upstart

Adjusting saw bar feed out pressure

1. Lower the grapple saw to the ground and shut off the engine.
2. Remove the saw motor cover.
3. Connect a suitable pressure gauge to the pressure test point (1).

Note! Place the pressure gauge so that the pressure easily can be checked from the operator's cabin when the saw function is activated.

Important!

Never adjust any hydraulic pressures without using a pressure gauge.

4. Start the engine and read the feed out pressure when the saw bar is completely fed out.

Note! Do not activate the saw function more than 5 seconds at a time.

5. Adjust the feed out pressure on the pressure regulating valve (2).
 - Increase the pressure by tightening the set screw.
 - Decrease the pressure by loosening the set screw.

For a proper pressure range, refer to Technical Data.

6. Remove the pressure gauge and assemble the saw motor cover.

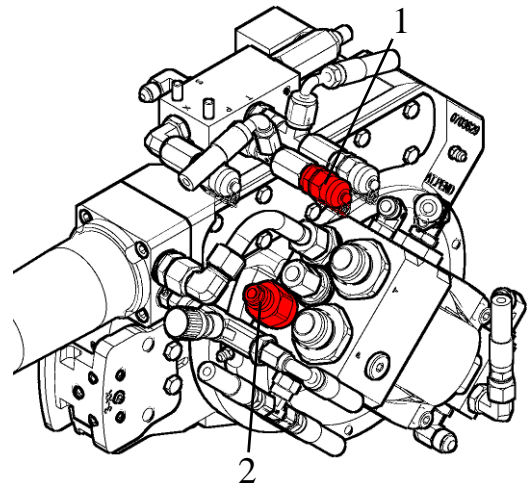

ill. 27 Adjusting saw bar feed out pressure

- 1 Pressure test point
- 2 Pressure regulating valve

Adjusting saw bar feed out

The saw bar feed out may need to be adjusted depending on the type of work the grapple saw is doing.

The saw bar feed out is adjusted with the check restrictor valve(1).

- If the knob on the check restrictor valve is screwed outwards, the saw bar will feed out faster.
- If the knob on the check restrictor valve is screwed inwards, the saw bar will feed out slower

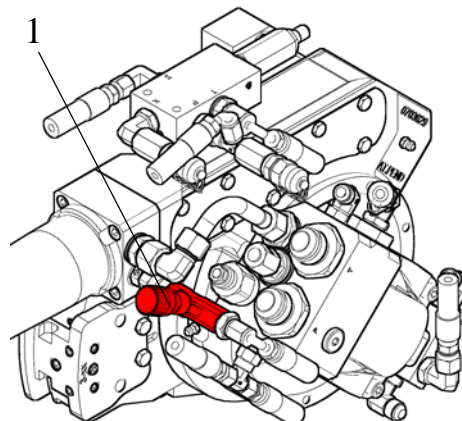

ill. 28 Adjusting saw bar feed out

1. Check restrictor valve

Adjusting saw bar retraction

When the saw bar retraction is properly adjusted, the saw bar should be fully retracted in 1,3 - 1,7 seconds.

⚠ Important!

The saw unit may be damaged if the saw bar retraction speed is too high.

The saw bar retraction speed is adjusted with the air-pressure in the air-tank (1).

- If the pressure is increased, the retraction speed will be higher.
- If the pressure is decreased, the retraction speed will be lower.

For a proper pressure range, refer to Technical Data

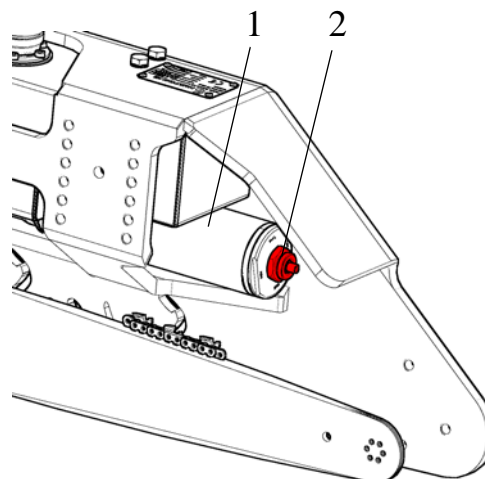

ill. 29 Adjusting saw bar retraction

- 1 Air-tank
- 2 Adjustment nippel for air-pressure

Adjusting chain tension pressure

1. Lower the grapple saw to the ground and shut off the engine.
2. Connect a suitable pressure gauge to the pressure test point (1).

Note! Place the pressure gauge so that the pressure easily can be checked from the operator's cabin.

Important!

Never adjust any hydraulic pressures without using a pressure gauge.

3. Start the engine and read the feed out pressure when the saw function is activated.
4. Adjust the chain tension pressure on the pressure regulating valve (2).
 - Increase the pressure by tightening the set screw.
 - Decrease the pressure by loosening the set screw.

For a proper pressure range, refer to Technical Data.

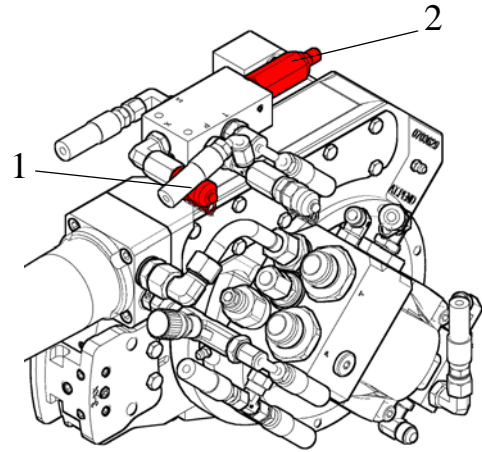

ill. 30 Adjusting chain tension pressure

- 1 Pressure test point
- 2 Pressure regulating valve

Bleeding the chain tension system

1. Lower the grapple saw to the ground and shut off the engine.
2. Open the bleeder valve (1) 1 - 2 turns with i.e a screw driver.
3. Push in the bar holder (2) completely and close the bleeder valve (1) with the bar holder in the inner position.
4. Start the engine and activate the saw function 4-5 times.
5. Repeat step 1-3.
6. Repeat this process after 30-60 minutes of operation.

Important!

Always bleed the system if there is any suspicion of air having entered the system, e.g. after replacing a hose or other component.

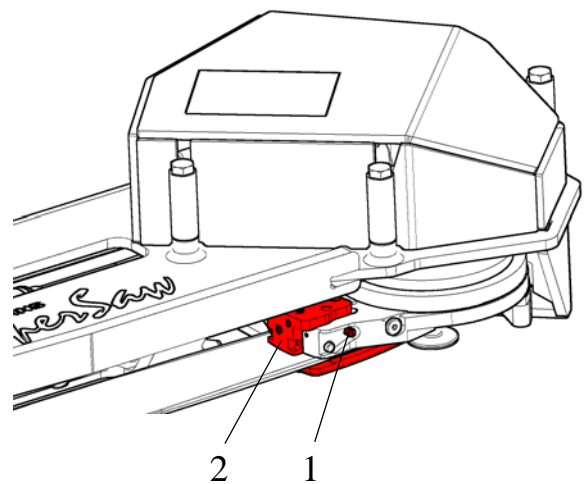

ill. 31 Bleeding the chain tension system

- 1 Bleeder valve
- 2 Bar holder

Procedures

Replacing saw chain

The first signs of a worn chain are abnormally long saw times and blue smoke emerging from the cut. When replacing the saw chain we recommend the following method.

Warning!

Before performing any maintenance or service work, lower the attachment to the ground and shut off the engine. Turn off any master shut-offs and do not allow personnel in the cab.

Caution!

When working on the saw chain always ensure the engine is shut off and wear safety gloves to prevent injuries. Remove the saw chain when making any adjustments or servicing the saw unit.

1. Place the unit steady on the ground with the saw unit facing up (when possible).
2. Depressurize the chain tension system by opening the bleeder valve (1) approx. 1 turn.
3. Retract the bar holder (2).
 - alt. 1 Slowly pull out the saw chain, until the locking pin (3) is possible to push in.
 - alt. 2 If the saw chain is missing. Slowly retract the bar holder (2) by hand, until the locking pin (3) is possible to push in.
4. Lock the bar holder (2) in place by pushing in the locking pin (3).
5. Remove the saw chain.
6. Make sure that the drive sprocket isn't worn or damaged. Replace if necessary. *See Replacing drive sprocket*
7. Install the new saw chain and slowly pull out the chain from the saw bar until the locking pin (3) releases.
8. Operate the saw carefully a few times to secure the pressure in the chain tensioner. If after replacing a chain it repeatedly jumps off the saw bar, you may have to bleed the system. *See Bleeding the chain tension system*

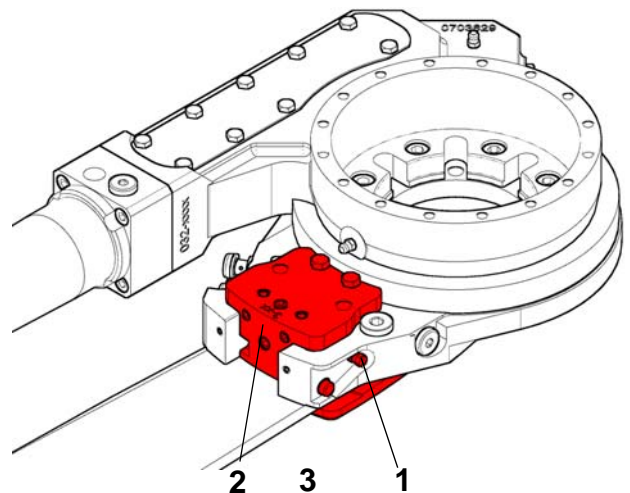

ill. 32 Replacing saw chain

Replacing saw bar



Warning!

Before performing any maintenance or service work, lower the attachment to the ground and shut off the engine. Turn off any master shut-offs and do not allow personnel in the cab.



Caution!

When working on the saw chain always ensure the engine is shut off and wear safety gloves to prevent injuries. Remove the saw chain when making any adjustments or servicing the saw unit.

1. Place the unit steady on the ground with the saw unit facing up (when possible).
2. Remove the saw chain. *See Replacing saw chain*
3. Loosen the guide screws (1) and remove the saw bar.
4. Install a new saw bar and tighten the guide screws (1). Torque 45 Nm
5. Install the saw chain. *See Replacing saw chain*

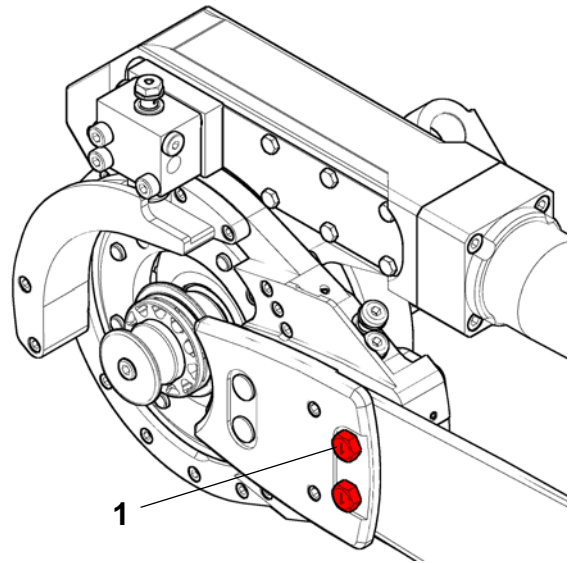

Replacing bar holder

When replacing the bar holder, always use the following method.

1. Place the unit steady on the ground with the saw unit facing up (when possible).
2. Remove the saw chain. *See Replacing saw chain.*
3. Remove the saw bar. *See Replacing saw bar.*
4. Disassemble the guide screws (1) and remove the bar holder (2) from the tension device.

⚠ Caution!

Never start the machine with the bar holder removed.

5. Inspect and clean the grooves (3) from any debris.
6. Install the bar holder (2) into the tension device. Fit the guide screws (1) into the grooves (3) and tighten the guide screws. Torque 20 Nm
7. Install the saw bar. *See Replacing saw bar.*
8. Install the saw chain. *See Replacing saw chain.*

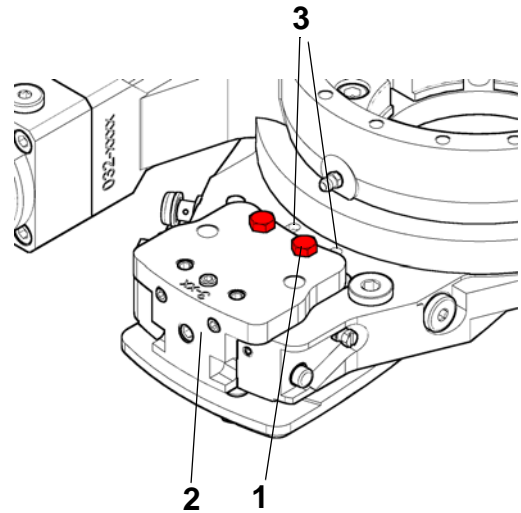

Replacing drive sprocket

Warning!

A worn or damaged drive sprocket may cause damage or breakage to the saw chain.

Warning!

Before performing any maintenance or service work, lower the attachment to the ground and shut off the engine. Turn off any master shut-offs and do not allow personnel in the cab.

Caution!

When working on the saw chain always ensure the engine is shut off and wear safety gloves to prevent injuries. Remove the saw chain when making any adjustments or servicing the saw unit.

1. Place the unit steady on the ground with the saw unit facing up (when possible).
2. Remove the saw chain. *See Replacing saw chain*
3. Remove the drive sprocket.
 - 1 Remove the cap screw. (1)
 - 2 Remove the chain catcher. (3)
 - 3 Remove the drive sprocket (4)
4. Install the new drive sprocket.
 - 1 Install the drive sprocket (4) onto the saw motor shaft.
 - 2 Clean the cap screw (1) and the threaded hole in the saw motor shaft.
 - 3 Apply oil to the thread on the cap screw (1)
 - 4 Install the lock washer (2) and the chain catcher (2) and tighten the cap screw (1).

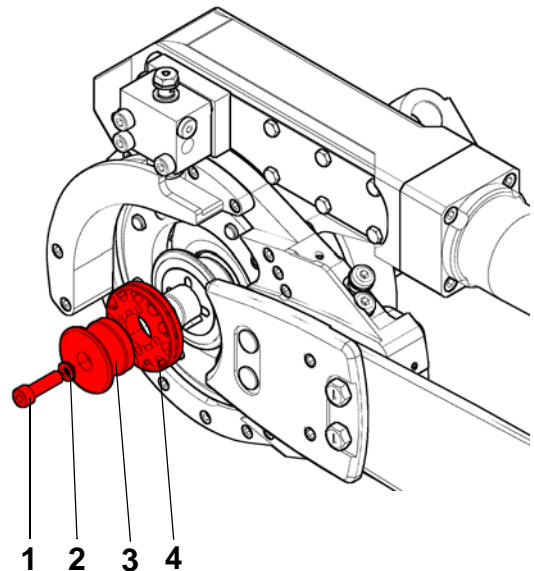

For a proper torque, see the following chart

Torque

Thread	Torque
M6	16 Nm
M8	38 Nm

5. Install the saw chain. *See Replacing saw chain*

Refilling chain lubrication oil



Warning!

Before performing any maintenance or service work, lower the attachment to the ground and shut off the engine. Turn off any master shut-offs and do not allow personnel in the cab.



Warning!

The attachment has sharp edges. Use proper wrenches and protective gloves when working on the attachment.

1. Place the unit steady on the ground and shut off the engine.
2. Clean the area around the refilling cap to avoid contamination of the lubrication oil tank.
3. Open the refilling cap and make sure that the strainer isn't missing or damaged.

Note! NEVER refill lubrication oil with the strainer missing or damaged.

Note! Debris in the lubrication tank can cause check valves in the lubrication system to malfunction.

4. Fill the tank with chain lubrication oil.
Note! NEVER use old motor oil or hydraulic fluid in the chain lubrication system. Always use a good quality chain lubrication oil.
5. Close the refilling cap.

Maintenance instructions

 **Warning!**

Before performing any maintenance or service work, lower the attachment to the ground and shut off the engine. Turn off any master shut-offs and do not allow personnel in the cab.

 **Warning!**

Never touch or stand close to the pressurized cylinders and hydraulic hoses.

 **Warning!**

The attachment has sharp edges. Use proper wrenches and protective gloves when working on the attachment.

Regular maintenance

Daily maintenance

Make sure that:

- Nothing abnormal has happened to the unit regarding fastener joints and hydraulic hoses.
- No damages or cracking have occurred on the unit.
- There is no leakage on the unit.
- At the beginning of each shift, always start with a sharp saw chain!

Tighten any loose items and repair any damages.

Lubrication

The saw unit should be lubricated every 8 to 200 hours of operation depending on the conditions that the unit is working under. The unit has 2 lubrication points as shown here. *See ill. 33.*

Note! Use a mineral oil based grease thickened with, or mixable with a lithium soap. The grease should be classified as L-XCCIB2 according to ISO 6743-9. Molybdendisulfid content max 3 %. Base fluid viscosity 170 to 220 cSt at 40°C. NLGI class 1-2.

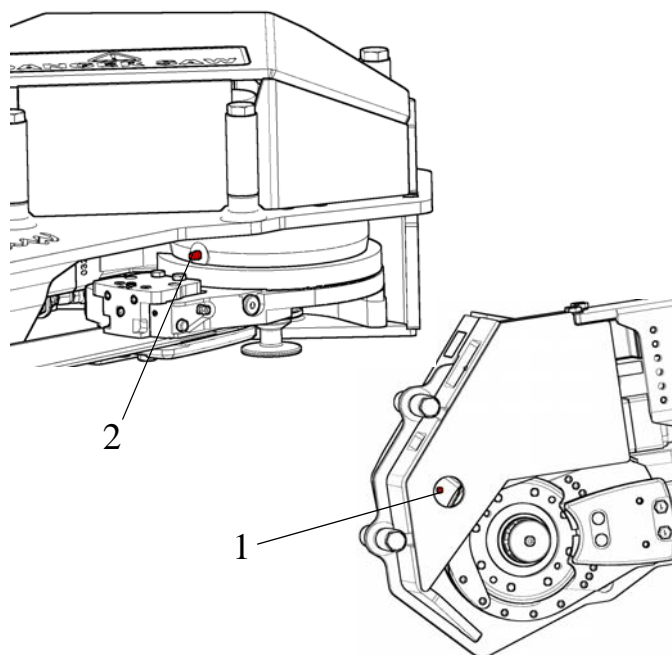

ill. 33 Lubrication points

1. Housing, 1 pcs.
2. Bearing, 1 pcs.

The first month of operation

Fasteners

Tightening of the all fastners should be made once a week during the first month of operation.

HULTDINS
SuperSaw™



0116-7000247-EN

Hultdin System AB
Skolgatan 12, SE-930 70 MALÅ, Sweden
Tel +46 953 418 00, Fax +46 953 418 01
E-mail: sales@hultdins.se

Hultdins Inc.
P.O. Box 1205, 22 Morton Ave. East
Brantford, Ontario, Canada N3T 5T3
Tel (519) 754-0044, Fax (519) 754-1569
E-mail: info@hultdins.com